

CAD FILE:

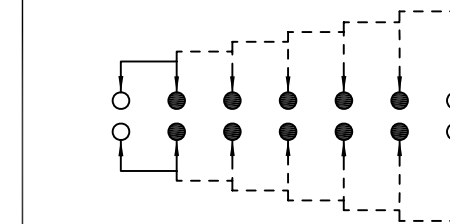

SCHEMATIC (NON-SHORTING)

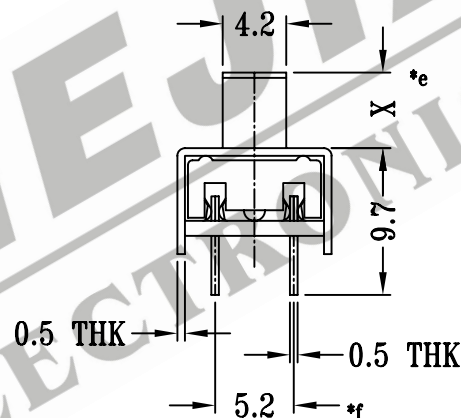
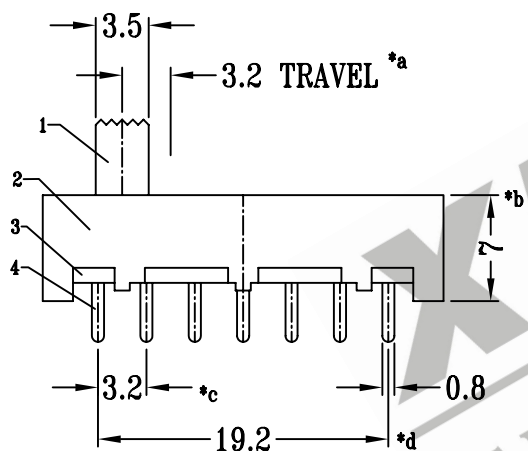
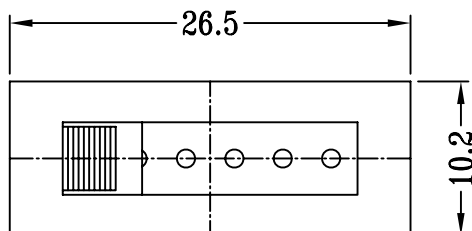
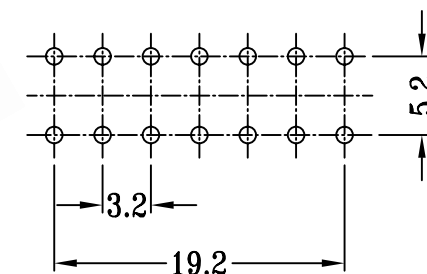

P.C.B LAYOUT

注:带*表示关键尺寸(6个)

NO.	PARTS	MATERIALS	Q'TY	FINISH	TOLERANCE UNLESS SPECIFIED	SHENZHEN XIEJIA ELECTRONICS CO.,LTD.					
8						ISSUE		DATE		DESCRIPTIONS OF REVISION	APPD.
7	STEEL BALL	STEEL	1	NATURAL	WITHIN: 1.5±0.1mm OVER: 1.5±0.2mm	TITLE: VERTICAL SLIDE SWITCH		UNIT: mm	DRWG NO.: XJ-DR-SS26F01-00		
6	SPRING	STEEL WIRE	1	TEMPER		MODEL: SS-26F01		SCALE: 2:1	DWN.	ZHOUYU	2002-5-14
5	CONTACT CLIP	PBS STRIP	2	Ag PLATED		ALL MATERIALS MUST BE COMPLIANT TO ROHS			CHK'D	FANGYING	2002-5-14
4	TERMINAL	BRASS STRIP	14	Ag PLATED OVER Ni PLATED					APPD.	KANGXINAN	2002-5-14
3	BASE	PHENOLIC RESIN	1	NATURAL							
2	FRAME	STEEL STRIP	1	Ni PLATED							
1	KNOB	POM	1	BLACK							